

Lessons Learned from ELFIN



Ethan Tsai, PM
Vassilis Angelopoulos, PI
Ryan Caron, CE

1. Mission Overview
2. Science!
3. AI&T Philosophy
4. Tunacan Antenna Design
5. Lessons Learned
 1. Coax Switches
 2. Assorted items
6. Questions



The twin ELFINs launch to space aboard the final Delta II rocket, Sept 15th, 2018. Also onboard were ICESat-2, Dave (CP-7), and SurfSat (UCF)

Mission Overview



- Mission Statement
 - ELFIN will explore the mechanisms responsible for the loss of relativistic electrons from the radiation belts, with the goal of contributing to predictive models of the magnetosphere, as well as equipping students with the necessary technical skills in industry
- ELFIN Spacecraft
 - Twin 3U+ spinning cubesats
 - Spin axis orbit normal, 20 RPM
 - Deployable mechanisms
 - Stacer boom, antennas
 - Built primarily by undergraduates
- Primary Payload Instruments
 - Energetic Particle Detectors (EPD)
 - EPD-Ions, EPD-Electrons
 - Measuring full pitch angle energy distribution of high energy particles
 - Fluxgate Magnetometer (FGM)
 - Measuring Earth's magnetic field
 - Detect EMIC waves

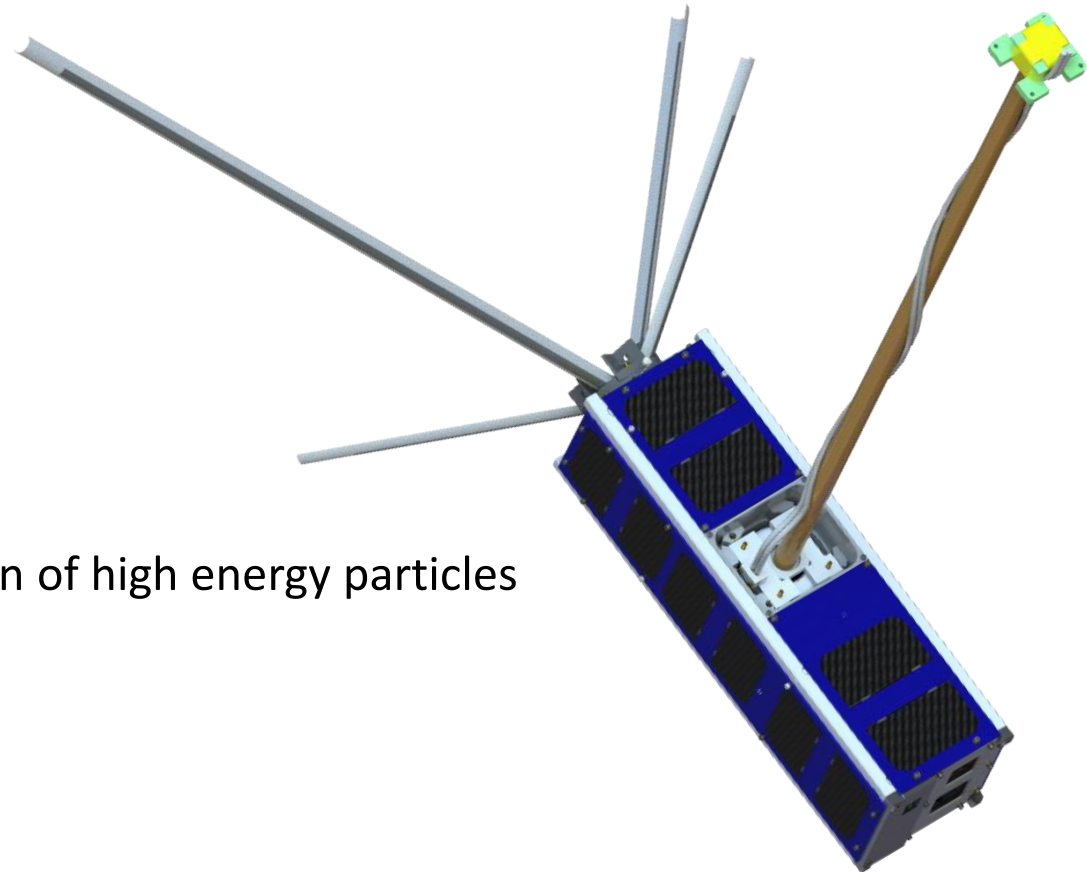

Meet the team!



- 1-3 part time staff mentors and student leads teams and project
- ~260 undergraduates have been a part of ELFIN
- Average team size of ~40 students during school year for spacecraft design, assembly, integration, and test
- Post launch ops team is currently ~15 students

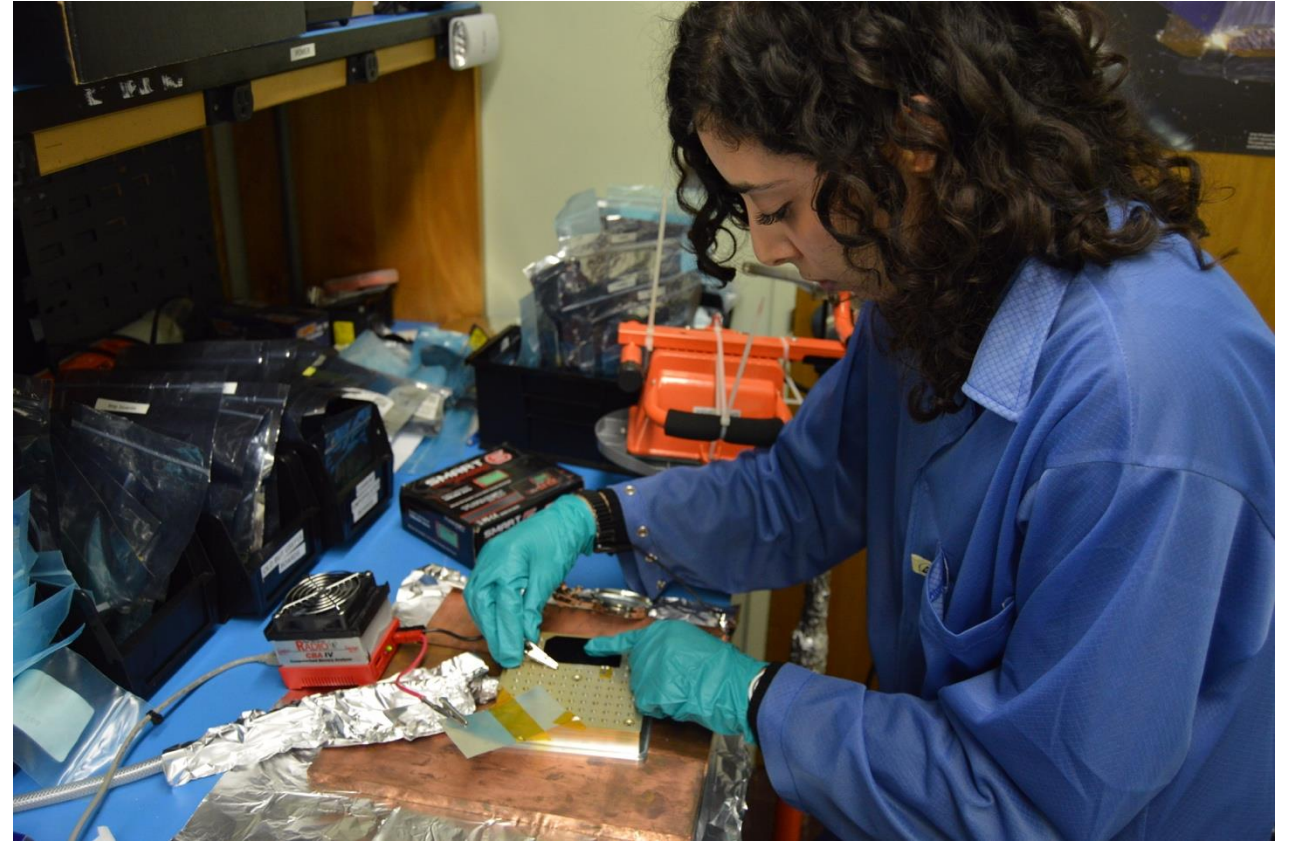

Current Mission Status

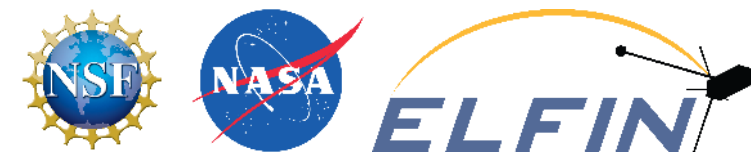

- Both ELFINs are healthy, although neither are fully commissioned yet
 - Post launch payload MSP software development took about 6 months
 - Ground science calibration campaign now near completion
- Near certain we can meet mission success
 - Want to measure a few substorms
 - Minimum mission success is defined by measuring energetic particle activity during at least one geomagnetic event
 - Expected to deorbit in early 2020
- Ground infrastructure is maturing well
 - Student team develops all ground assets
 - L0, L1 data will be made public via SPDF and SPEDAS when Primary Ops begins
 - L2 data will be made public once Science QA is complete

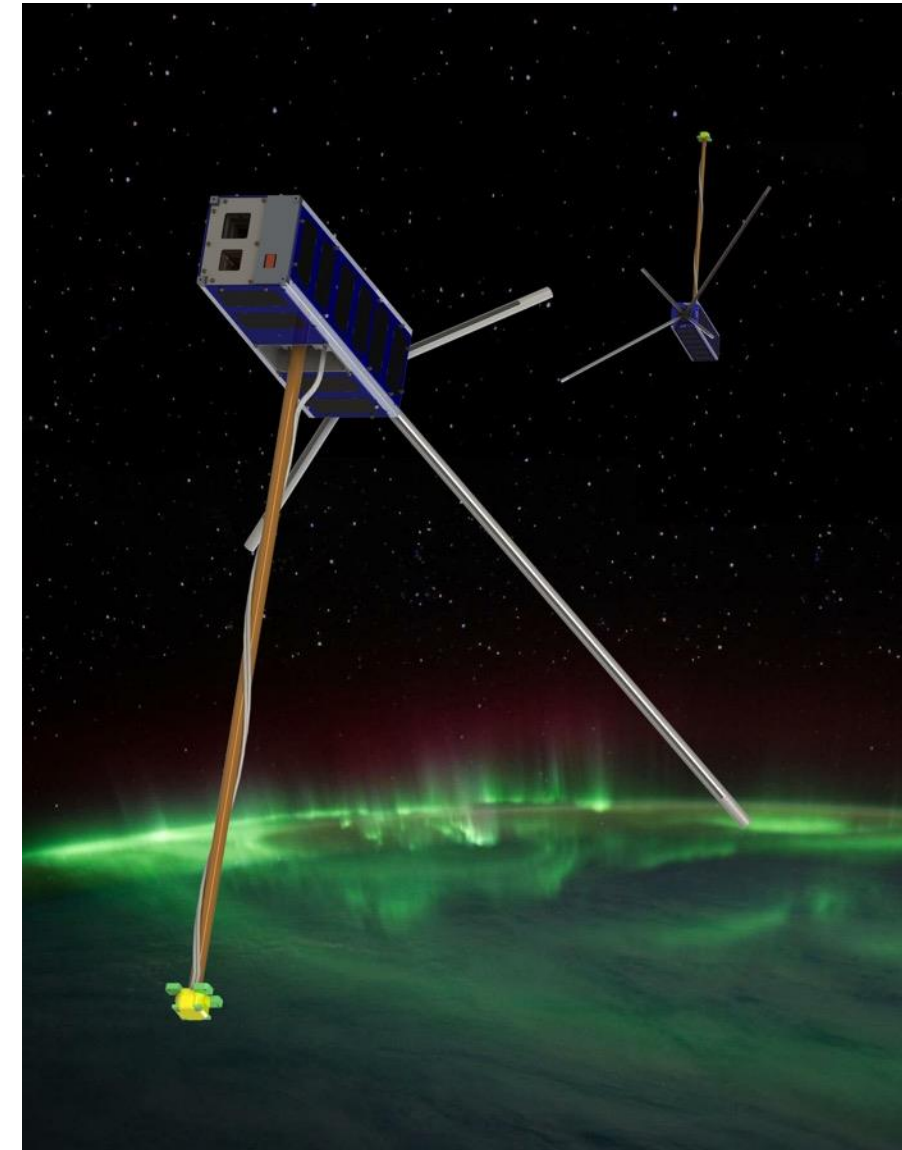

Thank yous!



- Thanks to NASA, NSF, and Aerospace Corporation for funding and support
- Our External Source Module allows us to stream data from others and drastically increase data volume, allowing simple interface with:
 - NASA Wallops UHF Support
 - SatNOGS database
 - Major props to DL4PD and DK3WN for making telemetry and beacon parsers
 - Major thanks to AD7NP, KB6LTY for listening to us a ton
 - As well as many others (too many to list)
 - StellarStation
 - New addition!

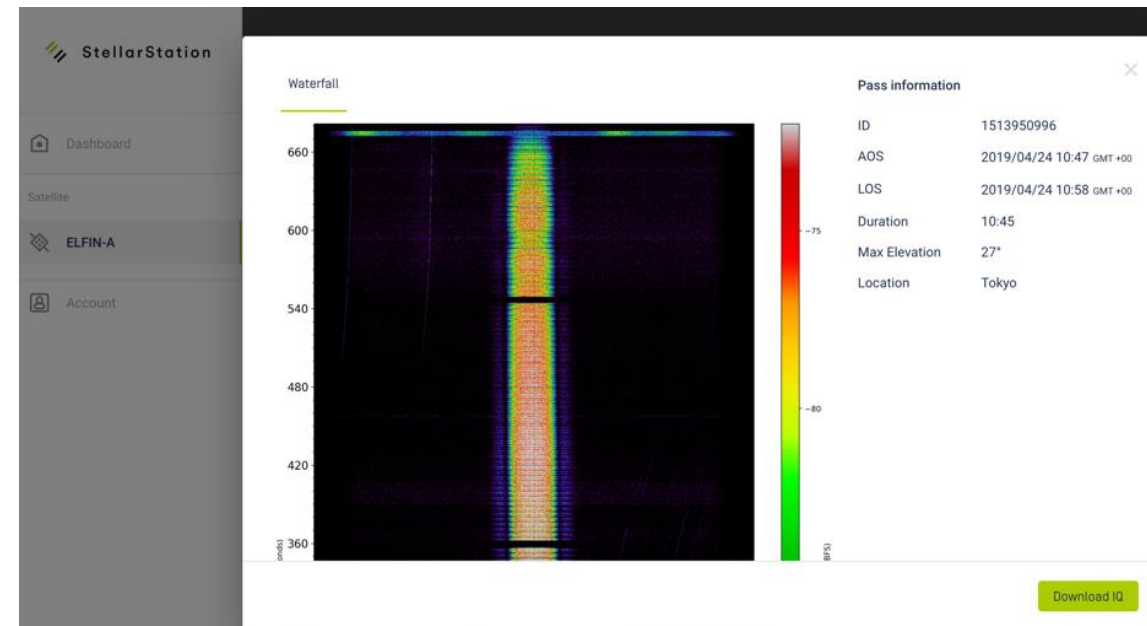

Science!

ELF-A EPD-E Energy Spectrogram

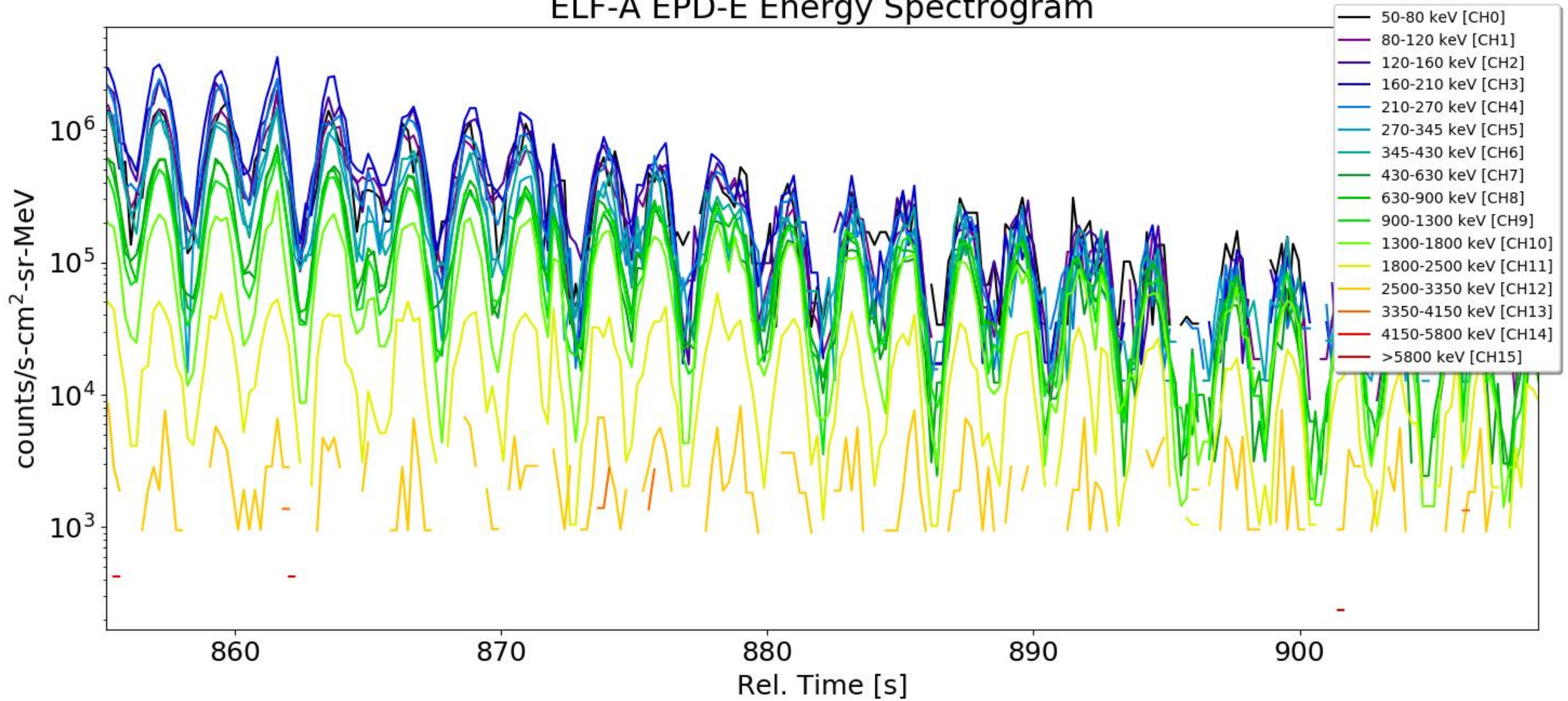

Science Data Takeaway



- Zoom in on data shows spin tones (trapped fluxes every 2 sec, current spin period of 4 sec) and counts that increase/decrease w/ radiation belt crossing
- Counts match data from NOAA POES mission:
 - To equate them, divide POES counts by their energy bin widths. This gives similar numbers to concurrent ELFIN measurements
- Future work for ELFIN A:
 - Minor tuning of thresholds (noise floor for low energies)
 - Orbit long science collection (to match POES data)
 - Begin Primary Ops!
- **UCLA has built high quality instruments for a fraction of the cost of most space weather missions that can provide unique and valuable science**

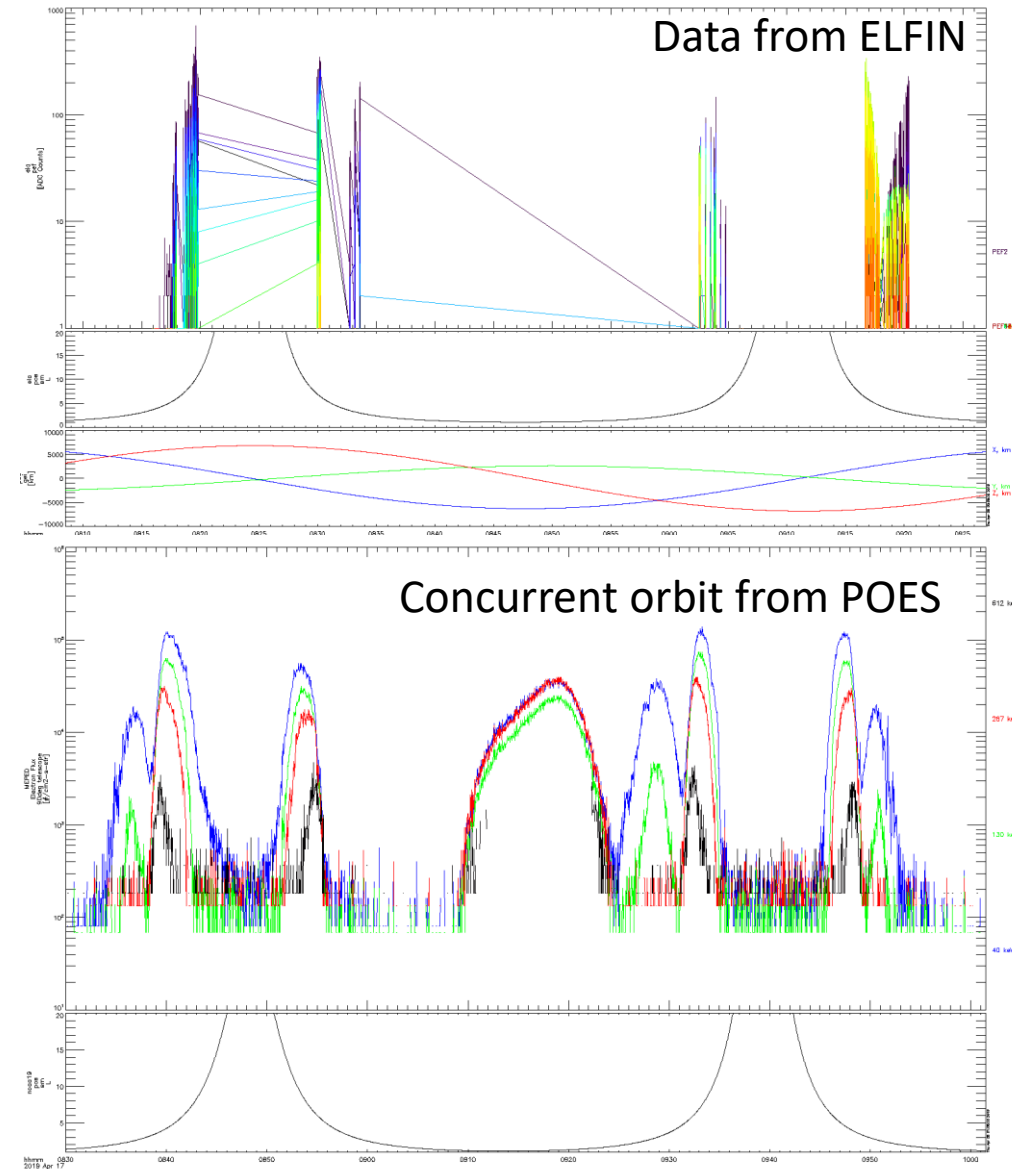

Energetic Particle Detector (EPD)



- Serves to measure the pitch-angle resolved fluxes of energetic electrons and ions precipitating from the radiation belts
- Sensor heads and supporting electronics fit in a volume of <math><1U</math>
- Both EPD-E and EPD-I can measure from 50 keV to 4 MeV
- We're happy to collaborate with new missions/partners who are willing to fly our flight proven particle detectors!
 - Confident we can improve performance on future missions even further!

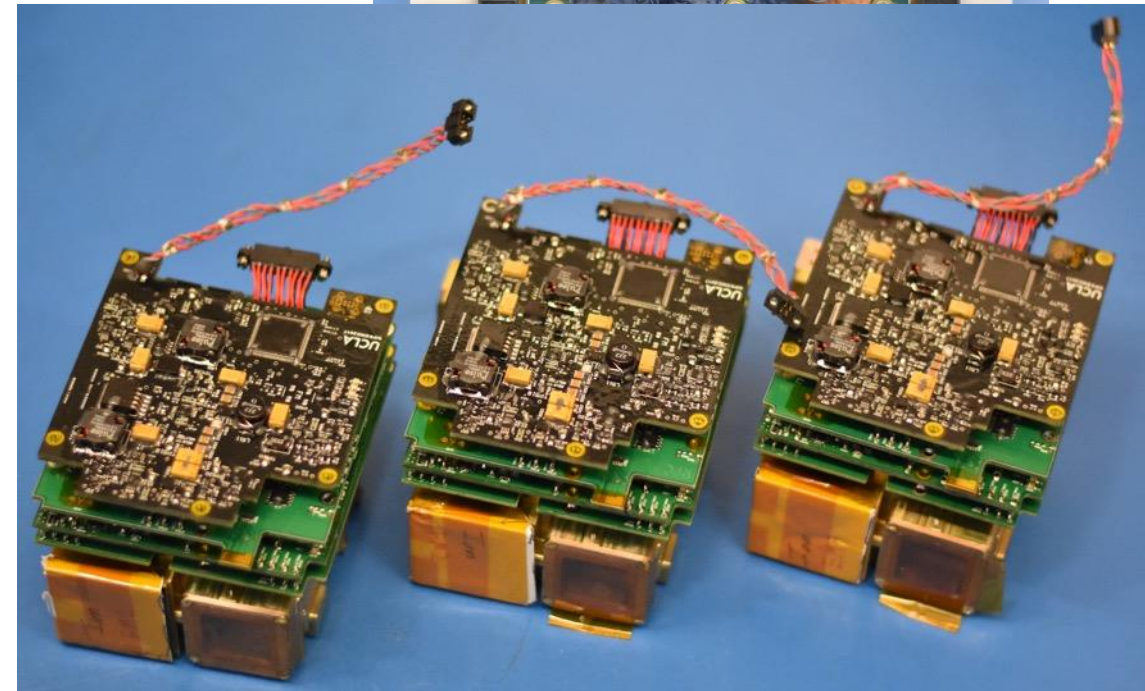
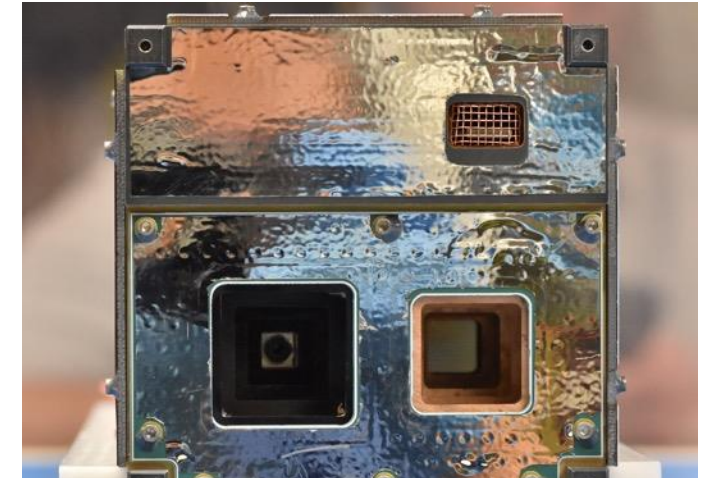

Fluxgate Magnetometer (FGM)



- Serves to provide spin sector information to the EPDs
 - Secondary science: be able to measure EMIC waves (<math><5\text{ nT}</math> amplitude, 3-5 Hz)
- Deployed on a 75 cm boom, sensor and deployment mechanism fits in volume of <math><1\text{U}</math>
- Supporting electronics for FGM fits in remaining volume
- Whole payload suite fits in 2U space
- 7.4 pT resolution, low noise and stable
- We're happy to collaborate with new missions/partners who are willing to fly our flight proven magnetometers!
 - New design flew on Insight and will fly on Europa Clipper (ICEMAG) and Psyche

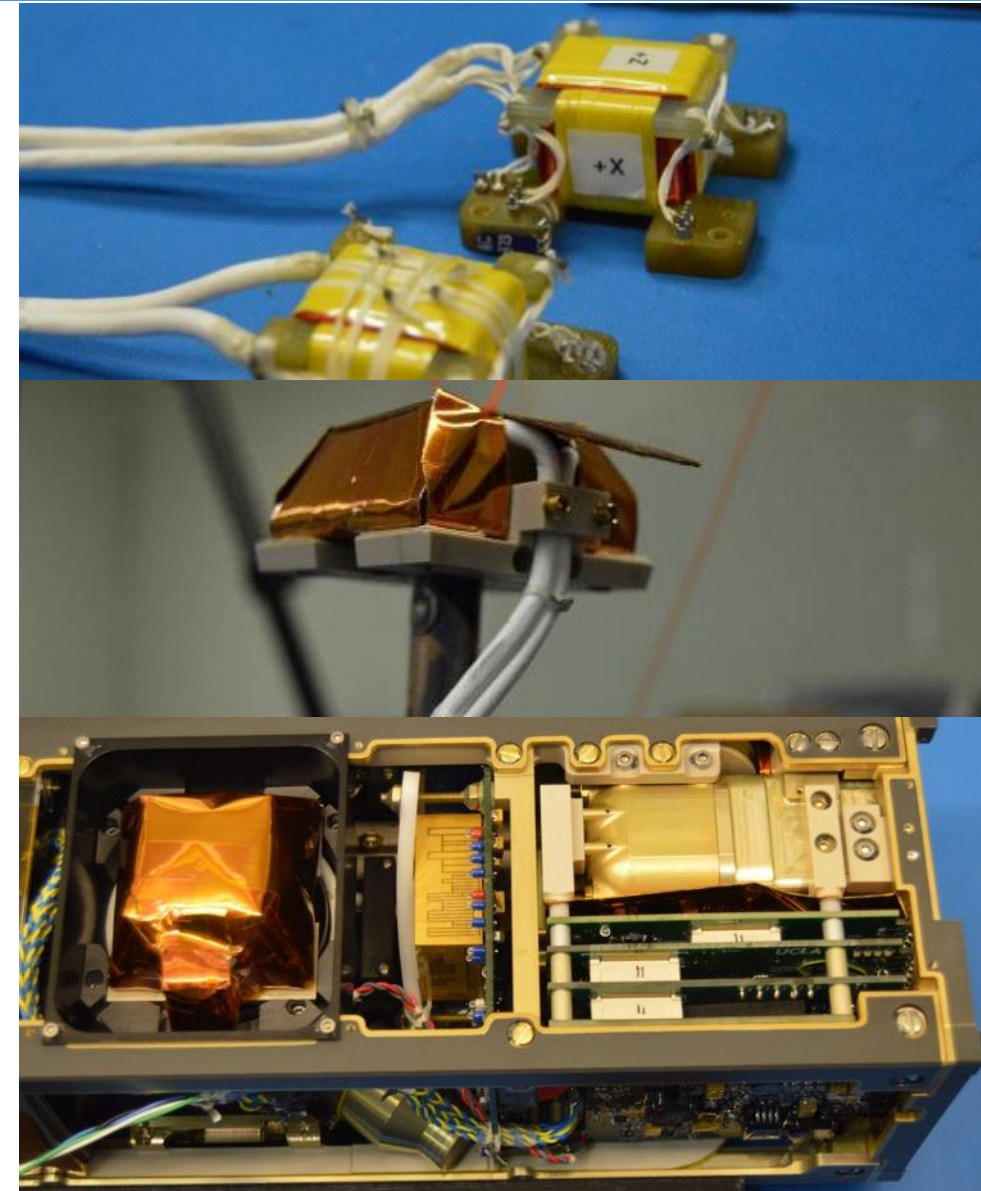

ELFIN Design

Expanded View

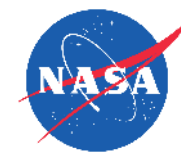

Instruments Stack



EPD-I

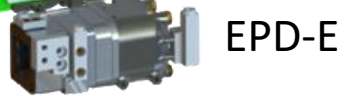

EPD-E

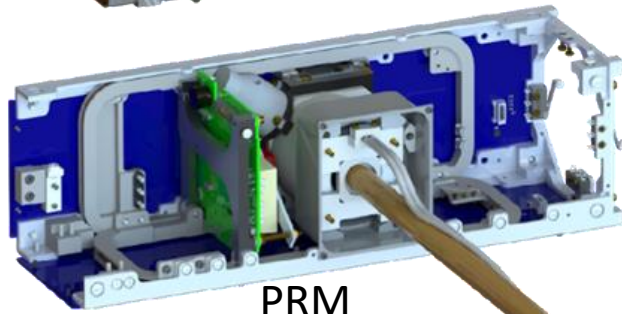

PRM



Avionics



Batteries

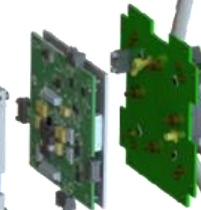

He-82

Stacer

FGM

UHF

VHF

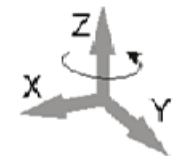

Assembly, Integration, & Test

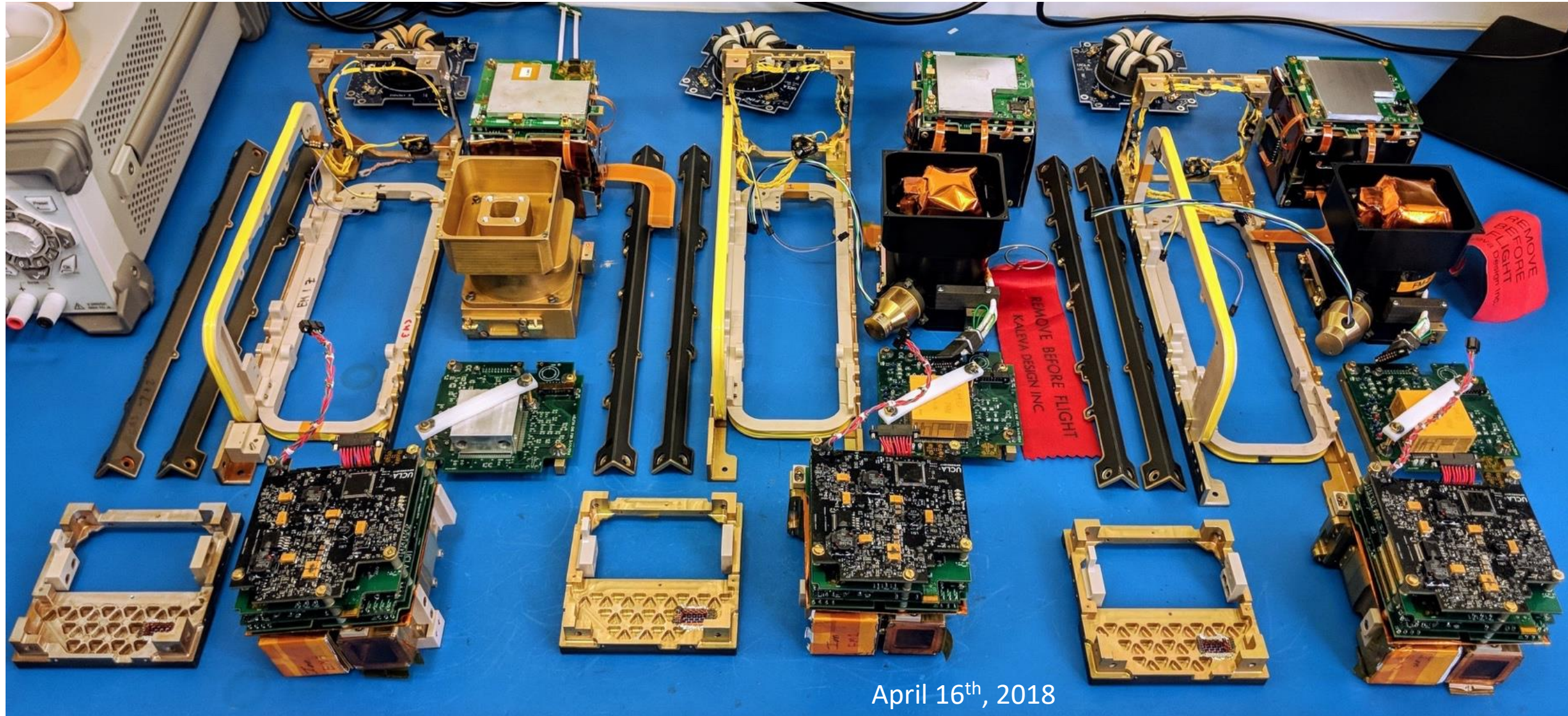
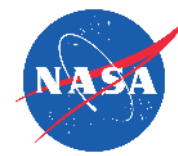

April 16th, 2018

Assembly, Integration, & Test



- Full Flight Integration and Testing of all 3 models took 4 months
- Staggered Parallel Approach
 - EM3 was a pathfinder: follow procedures and techniques laid out in EM3 assembly
 - Same personnel that worked on the EM subassemblies worked on FMA and FMB assemblies
- Functionality tests of sub-assemblies were always performed before further integration
- Make a lot of spares!

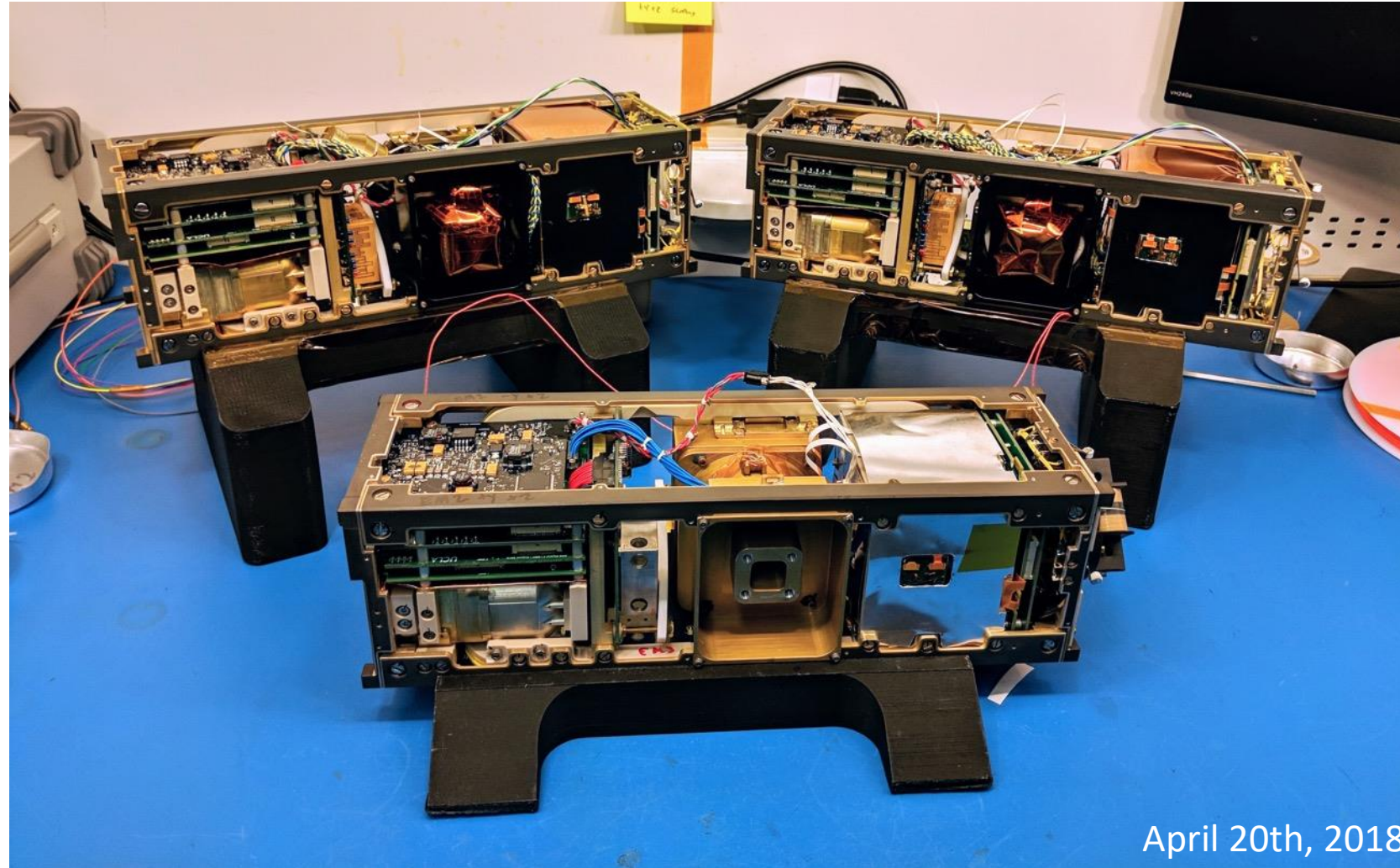

April 20th, 2018

Mechanical Tests

- Shock tests using CalPoly's hammer pendulum apparatus



Deployables Overview

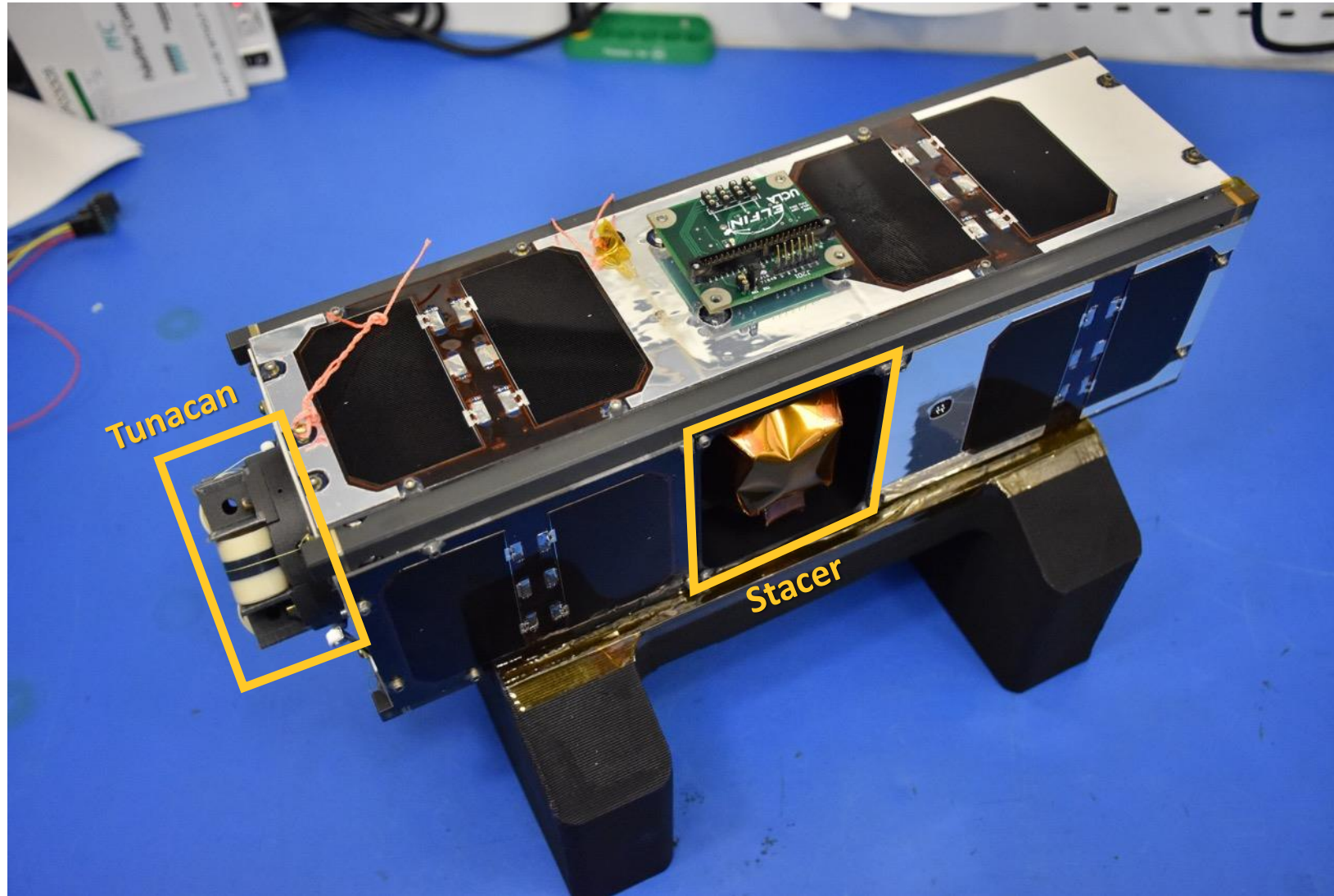

Tuna Can Overview

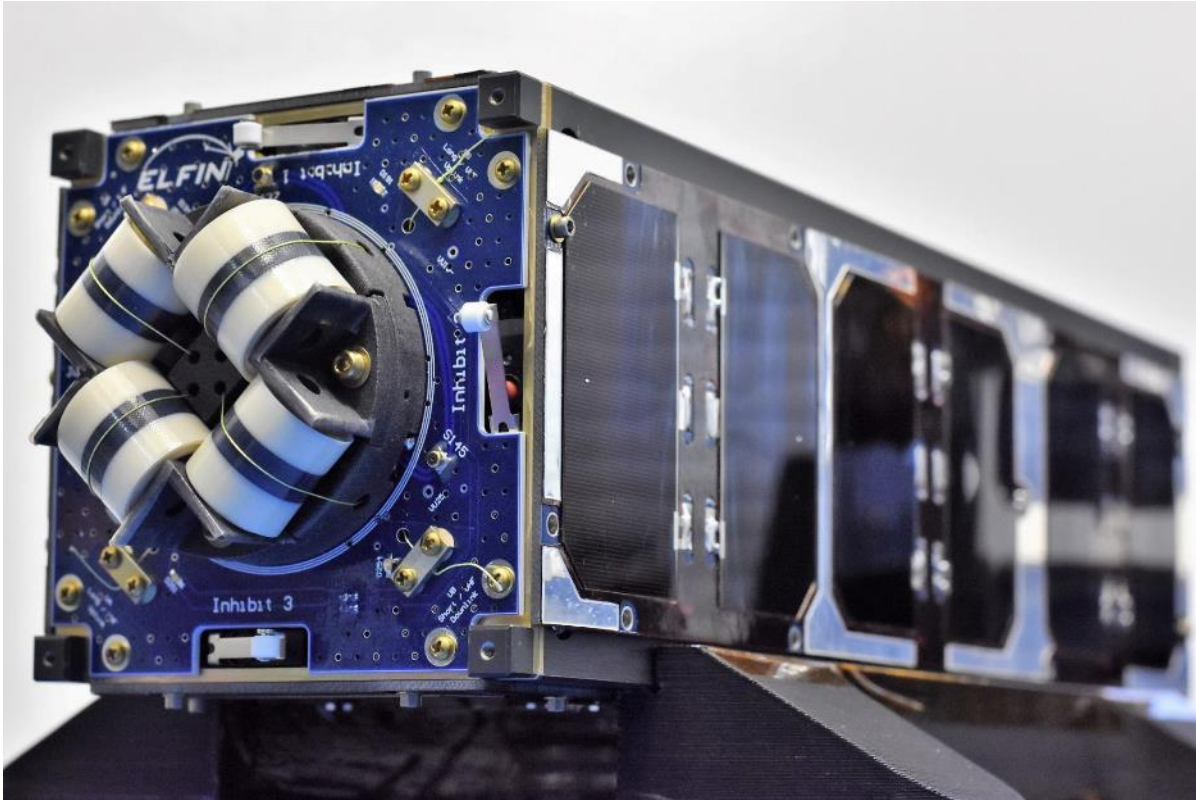

Stowed Configuration

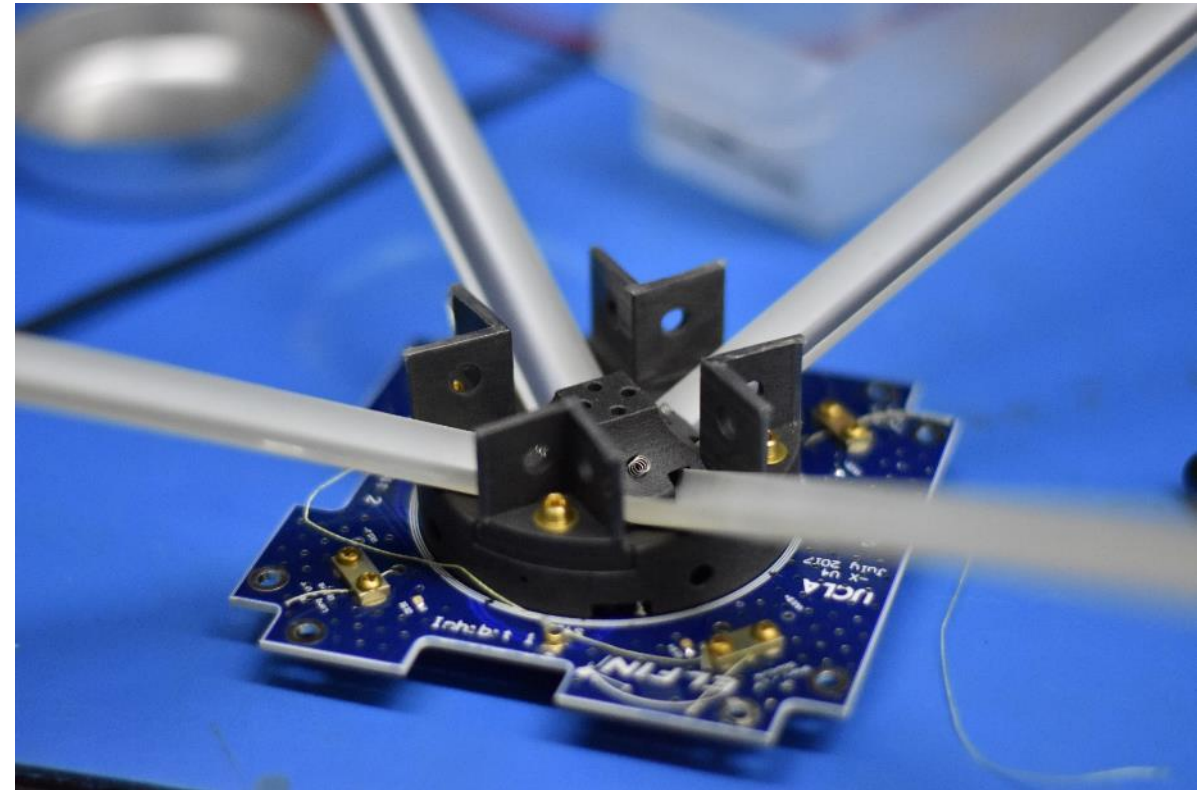

Deployed Configuration

Tuna Can Overview

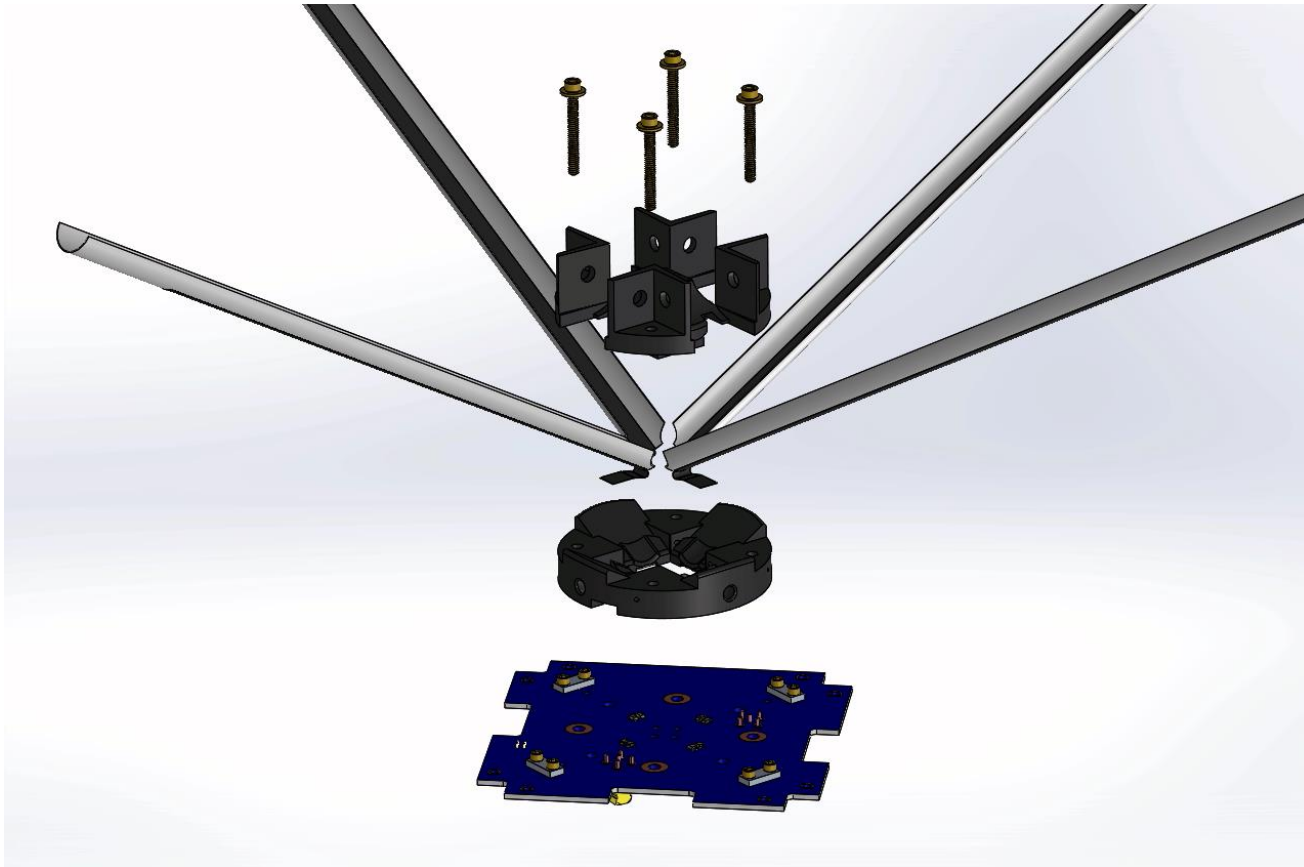

Expanded View Assembly



LoadPath Antenna + the Rattail

Tuna Can Overview

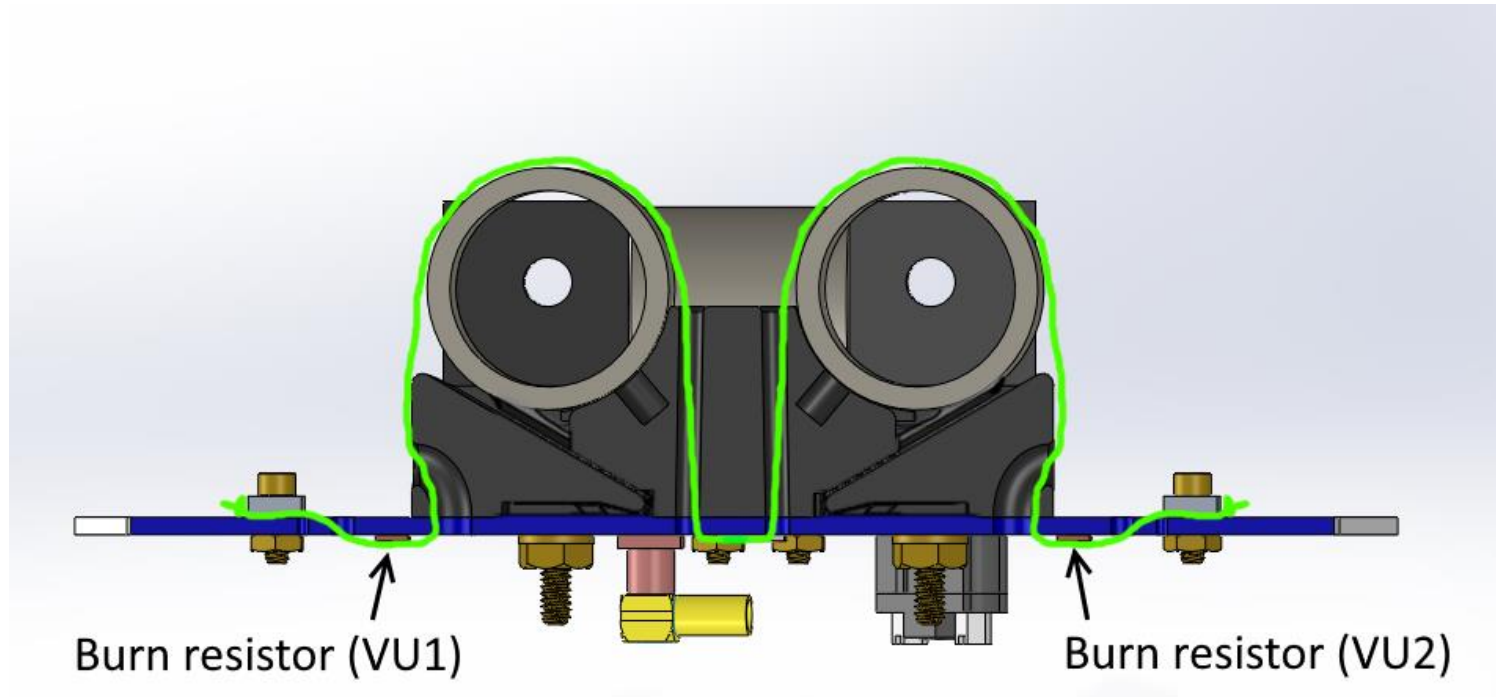
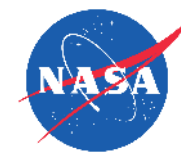

Spectraline Routing

Tuna Can Overview

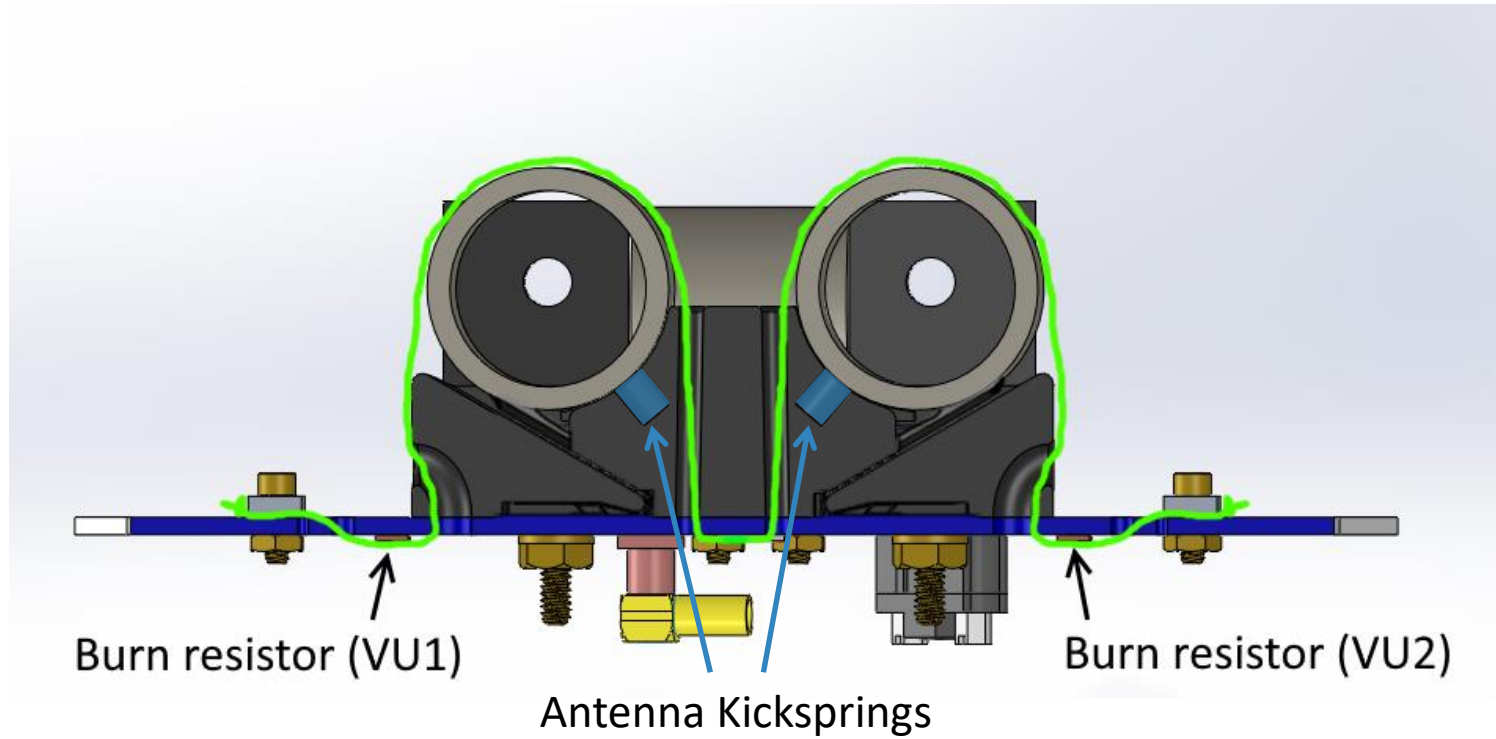

Spectraline Routing

Tuna Can Recap



- Tunacan is a 2 piece 3d printed Windform assembly
- Loadpath antennas are custom BeCu element sandwiched in between two pieces of fiberglass (2 VHF, 2 UHF)
- Burn resistors melt spectraline, releasing antennas
- Standardized antenna stowage caps and assembly jig
- Spring finger antenna connection
- Tapered walls and PTFE tape
- Deployment kick springs

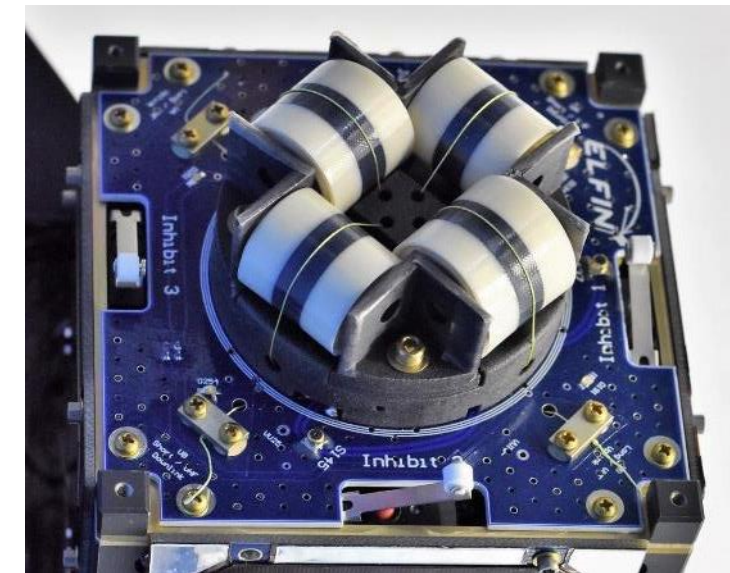
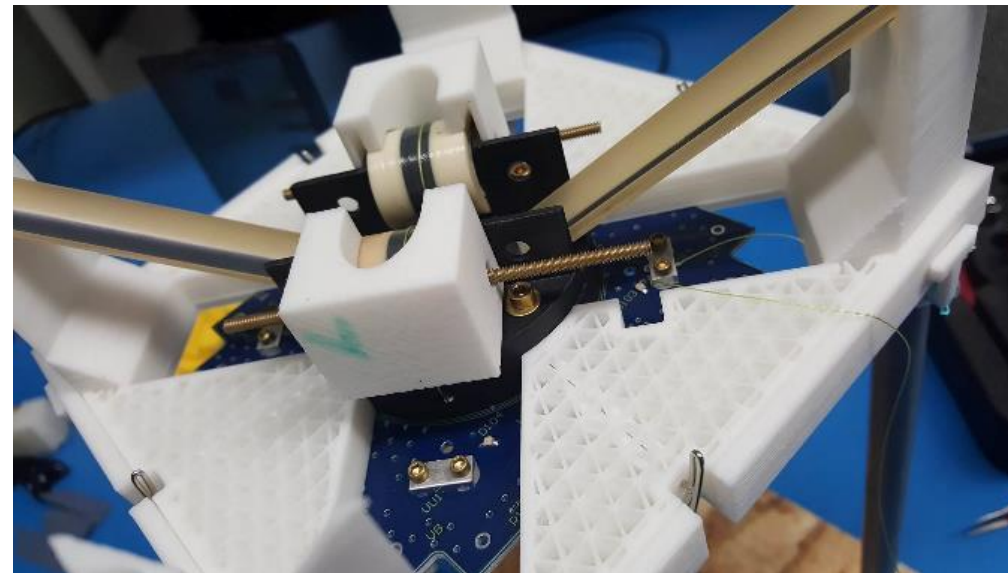
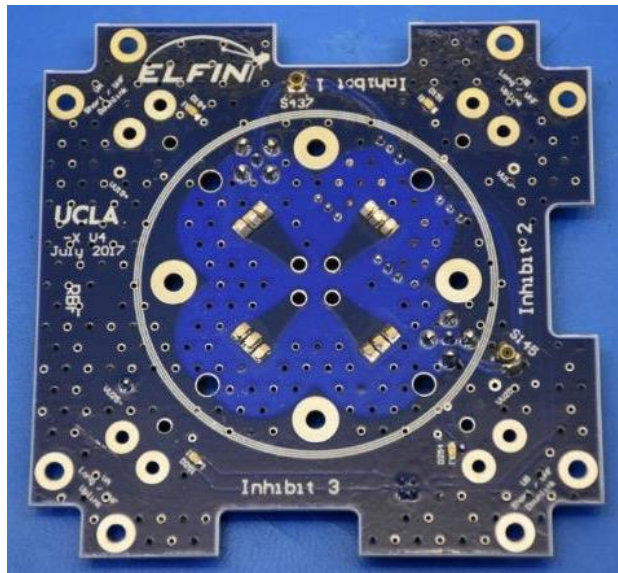
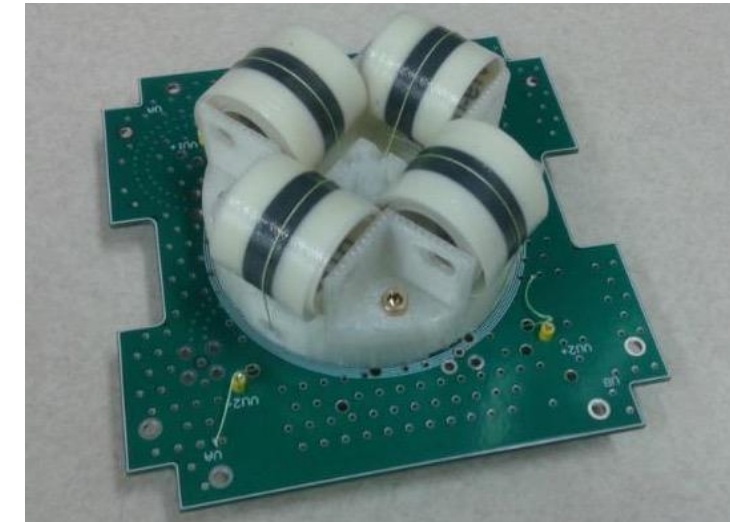

Lessons Learned

Coax Switches



- Problem: A lot of cubesats don't test their comm subsystem in TVAC
- Solution: test your radios in TVAC with the help of coax switches

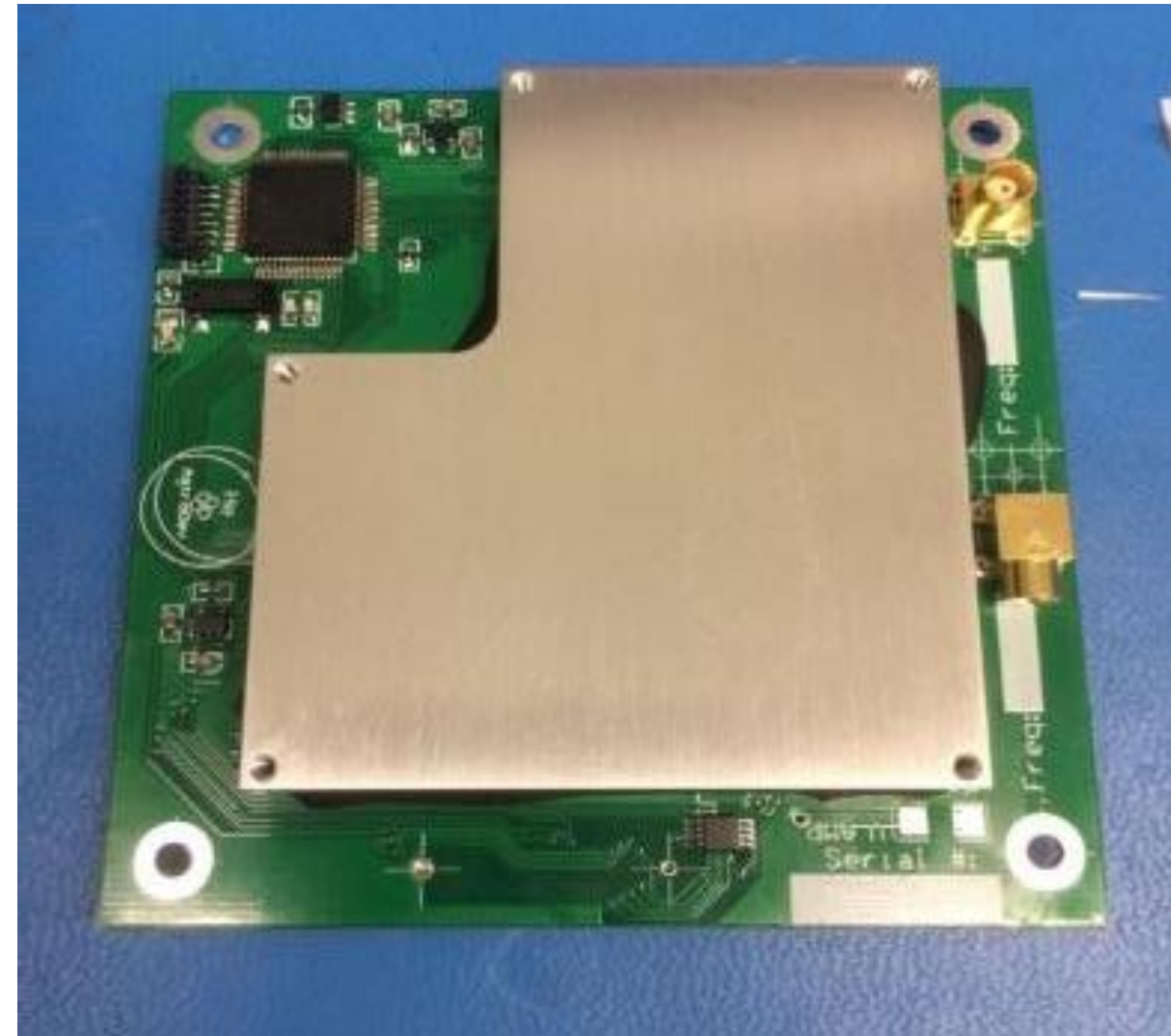

Astrodev He-82 radio (He-100 modified down to 82x82 mm)

Coax Switches

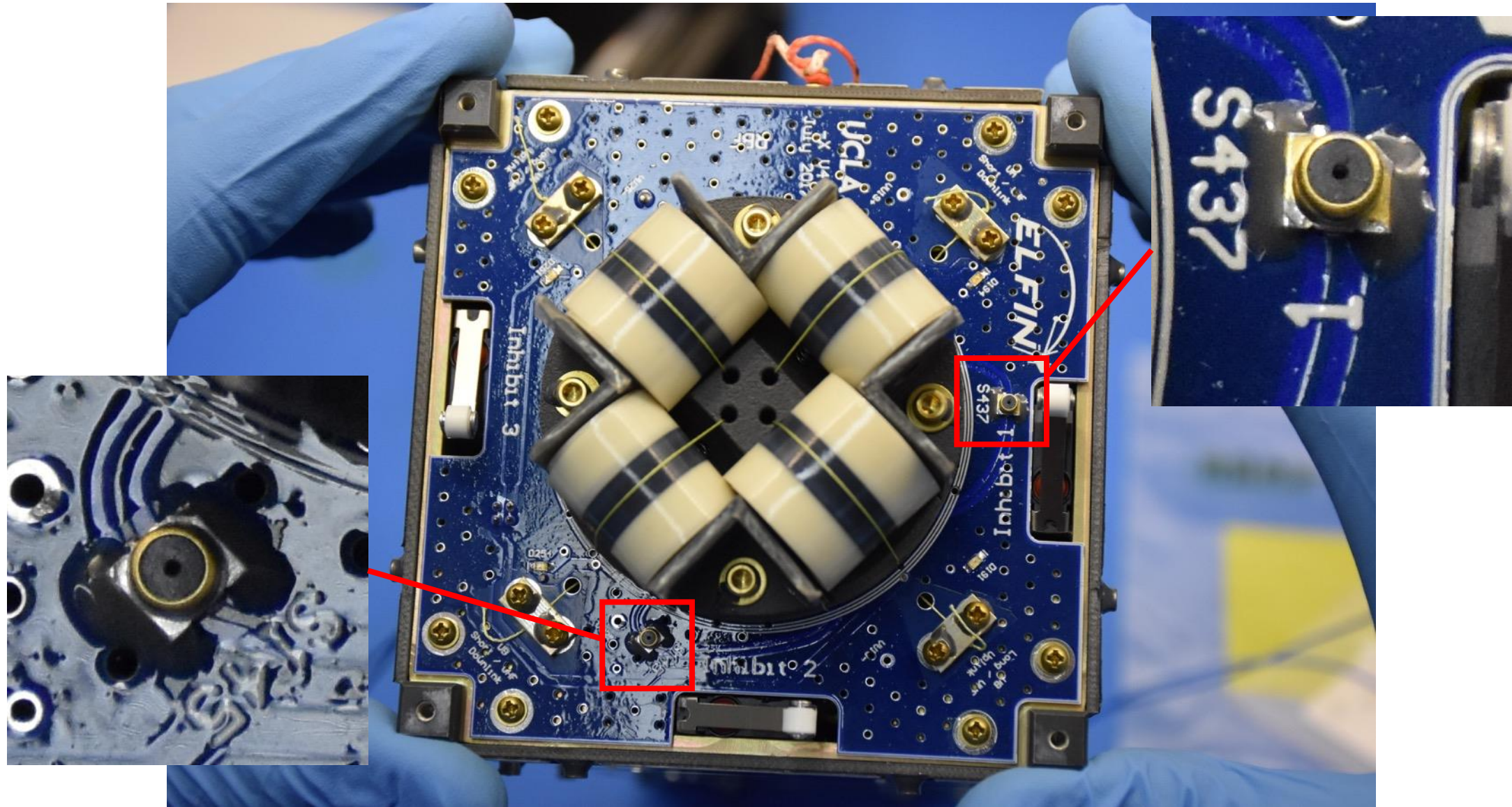
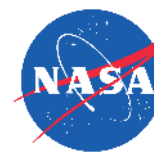

Coax Switches



- Digikey Part: H122453CT-ND
- Delicate connectors, easy to break
- A well made jig can hold coaxes in place, allowing for easy RF testing in TVAC

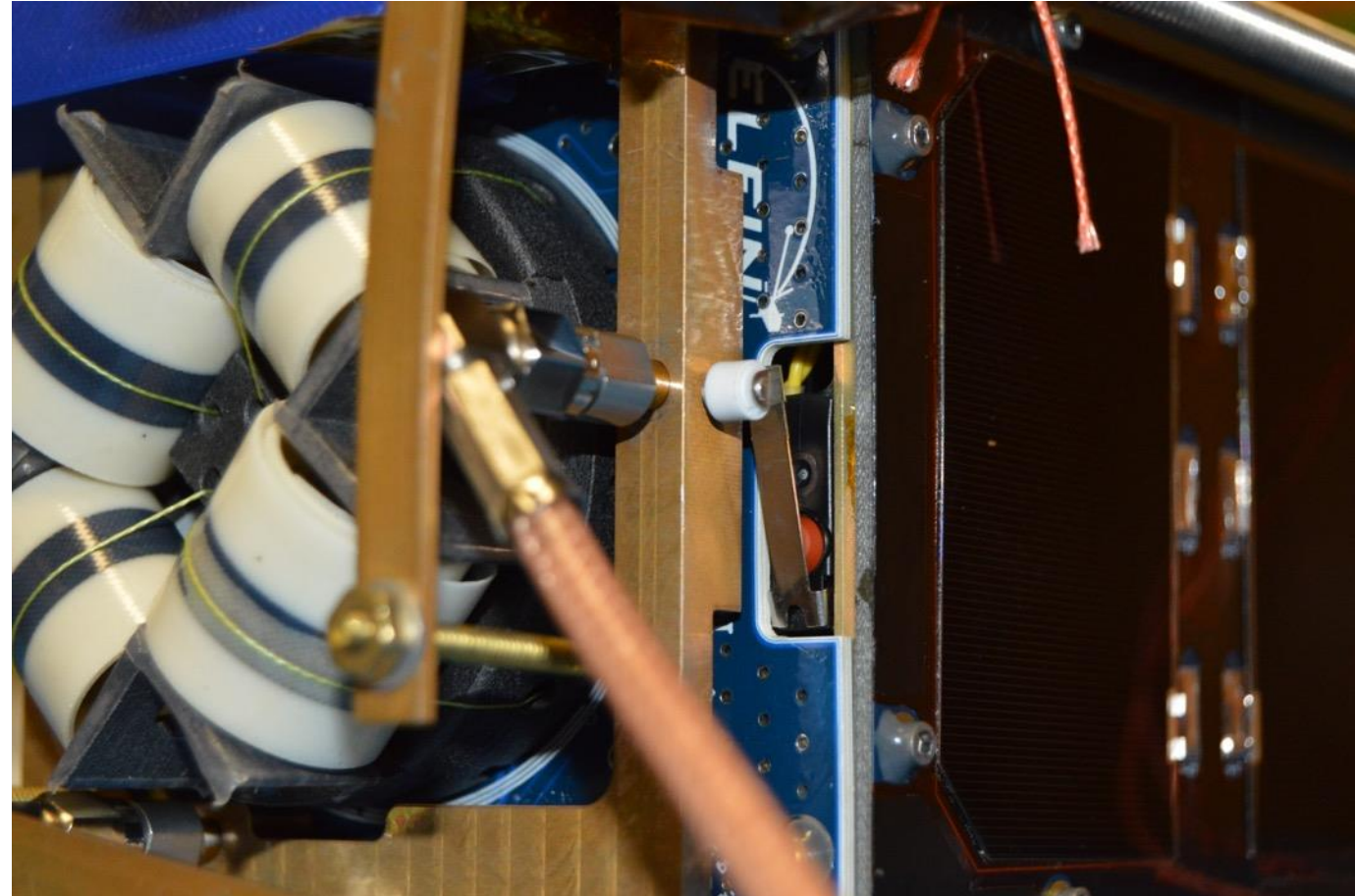

Check our website for more!

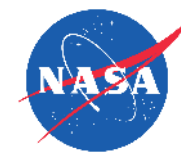

- CDR, PSR, and ORR material is all available there
- Plenty of data that we hope other cubesat teams can learn from
- <https://elfin.igpp.ucla.edu/review-material>

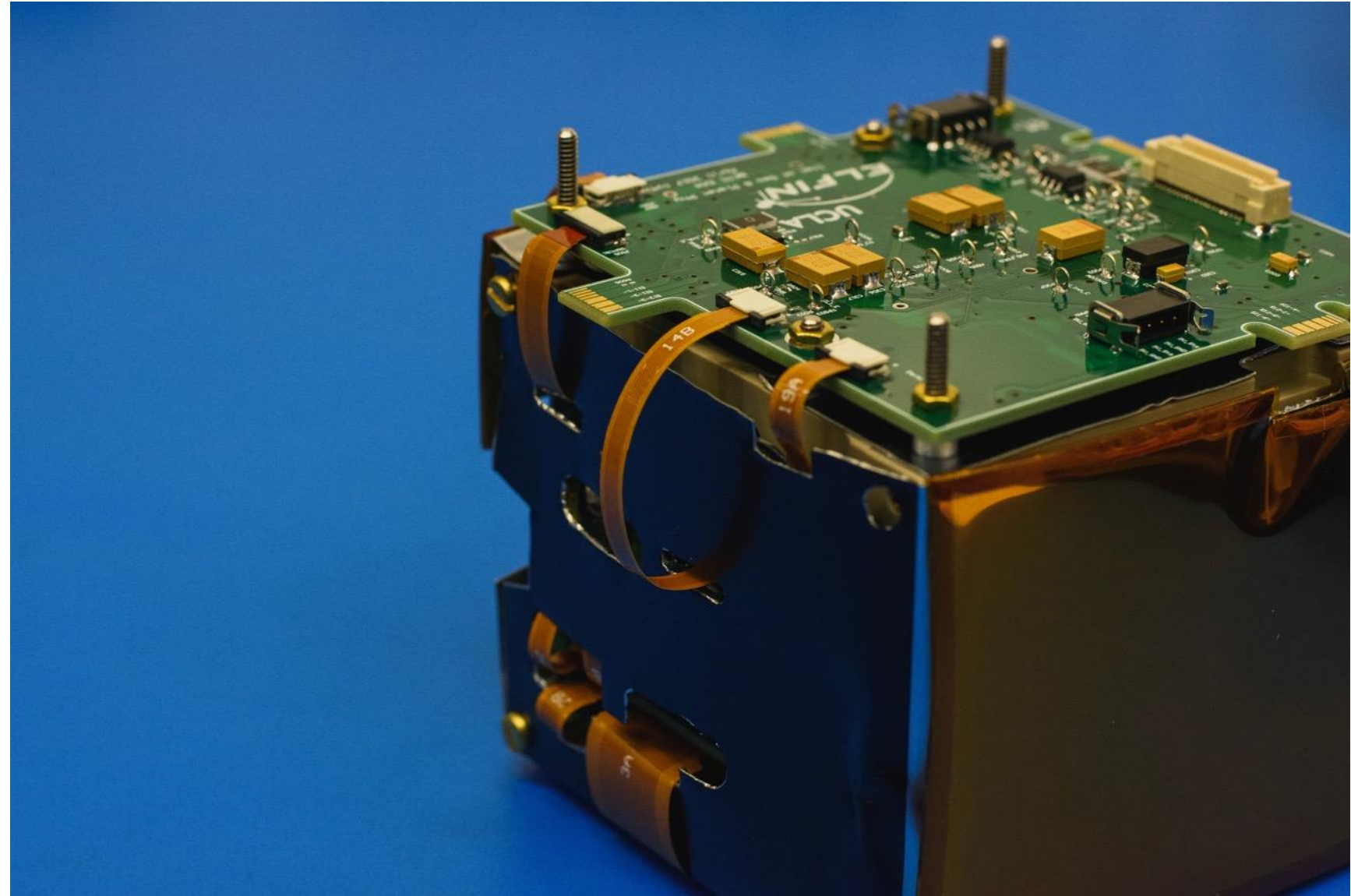

Assorted Lessons Learned

1. Do *a lot* more than DITL testing/launch integrator stipulated testing

ELFIN's testing included multiple TVAC cycles with regular CPTs over several weeks, range tests (OTA CPTs with MOC commanding at a orbit representative distance), spin tests (to validate ADCS), multiple deployment tests at all extremes environments, and more

2. Start planning mission ops earlier and develop it alongside flight software.

ELFIN mismanaged resources and personnel even though we had ample feedback telling us to. With the bulk of ops development occurring in the 3 months before launch, it was a bit rushed.

In addition, concurrent development of mission ops software ensures compatibility and properly tailored functionality.

Assorted Lessons Learned



3. Flight heritage != less testing

Because our FGM has extensive flight heritage, ELFIN management focused significantly less testing on it. Ground tests on the FGM were significantly more lax, and documentation was more sparse. Much harder to troubleshoot on orbit noise/performance issues when they crop up.

4. Focus as much on education and outreach as you do on primary mission success

ELFIN's mission has helped spawn Bruin Spacecraft Group (BSG) and UCLA's Amateur Radio Club (W6YRA).

In addition, management philosophy at ELFIN has always prioritized giving tasks that students were interested in above what was necessary while maintaining a professional work environment. The belief is that mission success will follow.

Over 200 ELFIN alumni are doing great things in industry.

Acknowledgements



Thank you to all of our sponsors, stakeholders, and contributors!



UCLA

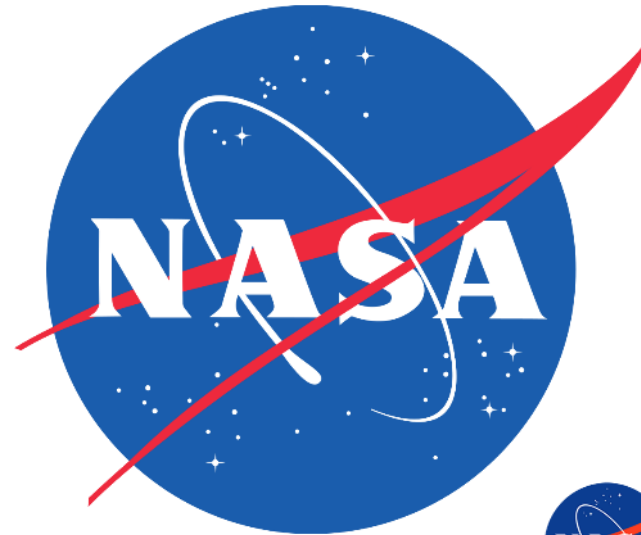
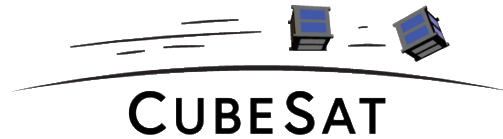

Shaun Murphy @ Northrop Grumman

Katharine Gamble @ UT Austin

Jim White WDOE @ Colorado Satellite Services

Mark Spencer WA8SME @ ARRL

Tony Monteiro AA2TX & Bob Davis KF4KSS @ AMSAT-NA

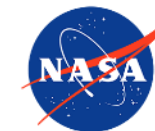

Jet Propulsion Laboratory
California Institute of Technology

